

VEHICLE SECURITY SYSTEM USING SMART SYSTEMS – AN OVERVIEW

A.Revathy¹, Ph.D Scholar, Assistant Professor,
Department of Commerce (E-Commerce), Nirmala College for Women, Coimbatore.

Dr.S.M.Yamuna², Head and Associate Professor,
Department of Commerce (Business Process Service),
PSG College of Arts & Science, Coimbatore

ABSTRACT:

In automobile field, the security and theft prevention are one of the main areas in present scenario. The security goals are achieved by vehicle security systems still with the increase in number of vehicles, the safety of vehicles becomes more complex and insecure, so there is more demand of safety and security of the vehicle rather than only monitoring its location. Presently the more intelligent systems are deployed with increasing popularity, which will also provide some additional benefits to the vehicle users. To fulfil all these requirements, the smart system needs to be developed. In this paper, we propose a smart system which will be based on Microcontroller, GPS, GSM and RFID technology, for the monitoring, controlling tracking and security of the vehicle. A vehicle tracking system combines the installation of an electronic device in a vehicle, or fleet of vehicles, with purpose-designed computer software to enable the owner or a third party to track the vehicle's location, collecting data in the process. Modern vehicle tracking systems commonly use Global Positioning System (GPS) technology for locating the vehicle, but other types of automatic vehicle location technology can also be used. Vehicle information can be viewed on electronic maps via the Internet or specialized software. This system helps to track the vehicle's location using Global Positioning System (GPS) and Global System for Mobile Communication (GSM). These systems constantly watch the movement of Vehicle and report the status on demand. When the theft is identified, the responsible person send SMS to the microcontroller, then microcontroller issue the control signals to stop the engine motor. To restart the vehicle motor, authorized person need to send the password to controller and open the door. This is more secured, reliable and low cost. The smart systems will help to the vehicle owner or operational manager of transport business to operate their vehicles with maximum security and efficiency by gaining the real time insights from the remote vehicle.

KEYWORDS:

Security, Vehicle Security Systems, Global Positioning System (GPS), Global Positioning System (GPS) , Global System for Mobile Communication (GSM) and RFID technology.

1. INTRODUCTION:

GSM and GPS based vehicle location and tracking system will provide effective, real time vehicle location, mapping and reporting this information value and adds by improving the level of service provided. A GPS-based vehicle tracking system will inform where your vehicle is and where it has been, how long it has been. The system uses geographic position and time information from the Global Positioning Satellites. The system has an "On-Board Module" which resides in the vehicle to be tracked and a "Base Station" that monitors data from the various vehicles. The On-Board module consists of GPS receiver, a GSM modem.

1.1 VEHICLE TRACKING SYSTEM:

A vehicle tracking system combines the installation of an electronic device in a vehicle, or fleet of vehicles, with purpose-designed computer software at least at one operational base to enable the owner or a third party to track the vehicle's location, collecting data in the process from the field and deliver it to the base of operation. Modern vehicle tracking systems commonly use GPS or GLONASS technology for locating the vehicle, but other types of automatic vehicle location technology can also be used. Vehicle information can be viewed on electronic maps via the internet or specialized software. Vehicle tracking systems are also popular in passenger vehicles as a theft prevention and retrieval device. Police can simply follow the signal emitted by the tracking system and locate the stolen vehicle. When used as a security system, a Vehicle Tracking System may serve as either an addition to replacement for a traditional Car alarm. Some vehicle tracking systems make it possible to control vehicle remotely, including block doors or engine in case of emergency. The existence of vehicle tracking device then can be used to reduce the insurance cost.

1.2 GLOBAL SYSTEM FOR MOBILE COMMUNICATION (GSM):

GSM modem, provided with a SIM card uses the same communication process as we are using in regular phone. The system is not limited to find the location of the target but also calculates the distance travelled between two stations. This system is user friendly, easily installable, easily accessible and can be used for various other purposes. After installation system will locate target by the use of a PHP page request to access Google maps for both static IP address users or using local host virtual server for free users. The system allows tracking the target anytime and anywhere in any weather conditions GPS Modem: GPS modules are popularly used for navigation, positioning, time and other purposes. GPS antenna receives the location values from the satellites. The system has an " Onboard

Module" which resides in the vehicle to be tracked and a "Base Station" that monitors data from b the various vehicles. The On-Board module consists of GPs receiver, a GSM modem. In GPS tracking system the location of vehicle is sent to remote place and it is done by GSM modem.

1.3 GLOBAL POSITIONING SYSTEM (GPS):

Global Positioning System (GPS) modem requires minimum 3 satellites to calculate the exact location. This modem communicates only in single way with microcontroller. This means that it can only transmit data to microcontroller. GPS Modem does not receive any data from microcontroller. At the same time GPS modem does not send data to Satellite, it only receives signal from satellites. Tracking system is very important in modern world. This can be useful in soldier monitoring, tracking of the theft vehicle and various other applications. The system is microcontroller based that consists of a global positioning system(GPS) and global system for mobile communication (GSM).

2. GSM & GPS BASED VEHICLE TRACKING SYSTEM:

GSM Modem Global system for mobile communication (GSM) is a globally accepted standard for digital cellular communication. GSM is the name of a standardization group established in 1982 to create a common European mobile telephone standard that would formulate specifications for a pan-European mobile cellular radio system operating at 900 MHz. A GSM modem is a wireless modem that works with a GSM wireless network. A wireless modem behaves like a dial-up modem. The main difference between them is that a dial-up modem sends and receives data through a fixed telephonenumber while a wireless modem sends and receives data through radio waves.

GPS is a space-based satellite navigation system. It provides location and time information in all weather conditions, anywhere on or near the Earth. GPS receivers are popularly used for navigation, positioning, time dissemination and other research purposes. The GPS consists of satellites that orbit the earth. These satellites are geosynchronous with an orbital period that is the same as the Earth's rotation period. So they maintain exactly the same position with respect to the earth below them. All the GPS satellites transmit radio signals, which are then captured by a GPS receiver and used to calculate its geographical position.

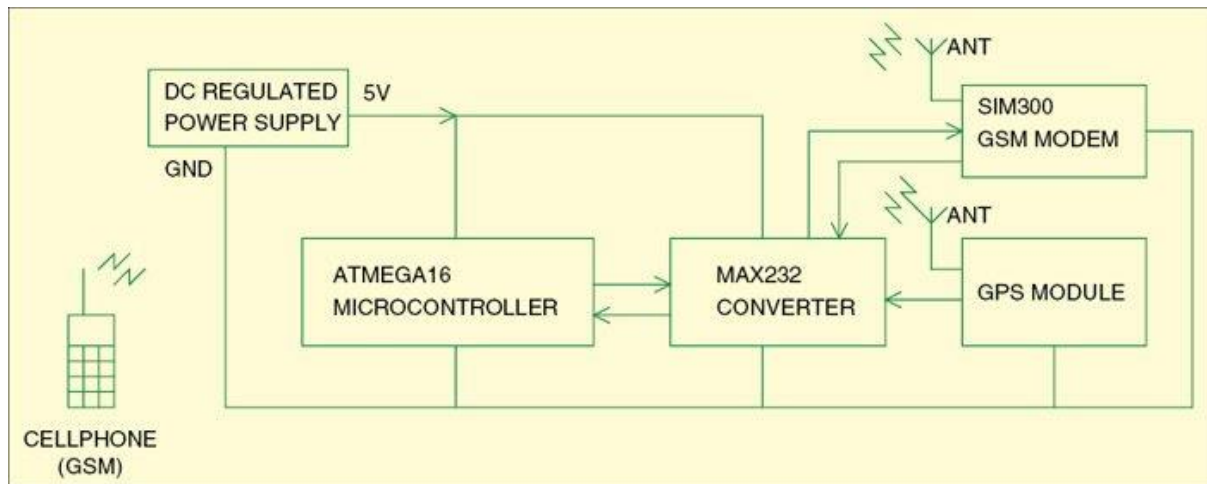

Fig. 1 shows the block diagram of the GSM and GPS based vehicle tracking system.

2.1 GSM MODEM

GSM is a standard set developed by the European Telecommunications Standards Institute (ETSI) to describe technologies for second-generation (2G) digital cellular networks. A GSM modem is a specialised type of modem that accepts a SIM card and operates over a subscription to a mobile operator just like a mobile phone. GSM modems are a cost-effective solution for receiving SMS messages because the sender is paying for the message delivery. To perform these tasks, a GSM modem must support an extended AT command set for sending and receiving SMS messages. It should also be noted that not all phones support this modem interface for sending and receiving SMS messages, particularly most smart phones like the Blackberry, iPhone and Windows mobile devices.

2.2 GPS BASED VEHICLE TRACKING SYSTEM: CIRCUIT DESCRIPTION

The circuit of a GSM and GPS based vehicle tracking system. It consists of a microcontroller, GPS module and GSM modem and 9V DC power supply. GPS module gets the location information from satellites in the form of latitude and longitude. The microcontroller processes this information and sends it to the GSM modem. The GSM modem then sends the information to the owner's mobile phone.

3. LITERATURE REVIEW:

1. Bang Liu et al, (2018) have in their paper made it possible to have an inexpensive tracking device with the use of an old smart phone. Tracking devices with GPS and GSM modalities are very expensive and also require a substantial investment.

2. V.Yamuna,G.Rupavani,et al.(2014) proposed GNSS based bus monitoring system. The main objective of this system is to reduce the waiting time of passenger in bus stop by sending information about the location of bus to the passenger through SMS.

3. Bhanu Prakash and K. Sirisha, (2014) the developers of this security system for a car have designed a security system to help prevent theft. The design has the following capabilities installed in it, GSM modalities so that smartphone installed in the car uses cellular network to track the car and report to the car users in case of a break-in.

4. APPLICATIONS AND ADVANTAGES:

1. Helps to locate your stolen vehicle easily using your mobile without any extra cost.
2. It can be used for trucks carrying valuable goods, to keep track of the status of delivery and location of the truck at all times.
3. The device ensures vehicle security and smooth fleet management.
4. Easily installation in any vehicle such as cars, boats and motorbikes. An SMS will inform you whether the vehicle is stationary or on the move.
5. Helps to track the vehicle. It reduces vehicle abuse and ultimately results in significant cost-savings for individuals and fleet owners

5. CONCLUSION:

Now days there are a huge need on the security and tracking system. In this paper, we have discussed the method of vehicle tracking and locking systems used to track the theft vehicle by using GPS and GSM technology which plays a big role in securing for both driver and passengers as a personal vehicle tracking or used in huge organizations in order to handle the situation of related vehicle remotely all the time. Based on the above discussions, it is evident that the proposed Microcontroller, GPS, GSM and RFID based smart system for the remote vehicle monitor, control, security and fuel management purpose, has a Business Intelligence capabilities. Hence, this smart system for vehicle monitoring, controlling and security will helps the vehicle owner or operational Manager of transport business to operate their vehicles with maximum security and efficiency by gaining the real time insights from remote vehicle to make the optimal and timely decisions.The presented system also is in a low cost with many helpfully features in order to make a secured and tracked system.

REFERENCE :

1. Bang Liu et al. (2018). A Low-Cost Vehicle Anti-Theft System Using Obsolete Smartphone. *Hindawi Mobile Information Systems*. 1-16.
2. N.Vijaylashmy, V.Yamauna,G.Rupvani,A.Kannaki at Vasantha Azhagu, (2014) GNSS based bus monitoring and sending SMS to the passenger, “*International Journal of Innovative Research in Computer and Application Engineering*,Vol.2,Special Issue 1,March2014.
3. Bhanu Prakash and K.Sirisha. (2014). Design and Implementation of a Vehicle Theft Control Unit using GSM and CAN Technology. *International Journal of Innovative Research in Electronics and Communications (IJIREC)*. 1 (4), 46-53.
4. Hu Jian-ming; Li Jie; Li Guang-Hui(2012), "Automobile Anti-theft System Based on GSM and GPS Module," *Intelligent Networks and Intelligent Systems (ICINIS)*, 2012 *Fifth International Conference on* , vol., no., pp.199,201, 1-3 Nov.2012
5. Supriya C, Dr. Bombale U. L.,Patil T.(2008) " An Intelligent Vehicle Control and Monitoring Using Arm " *International Journal of Engineering and Innovative Technology (IJEIT)*Volume 2, Issue 4, October 2012, ISSN:2277-3754, ISO 9001,2008
6. https://en.wikipedia.org/wiki/Vehicle_tracking_system